

## General Notes

- To reach best hatching result, please read the manual carefully before using
- 1- Package included \* 1, manual\* 1, Power code socket protection foam\* 1, power code\* 1, water kettle\* 1



- 2- Power cord socket



3- Ensure egg tray matched motor shaft connector

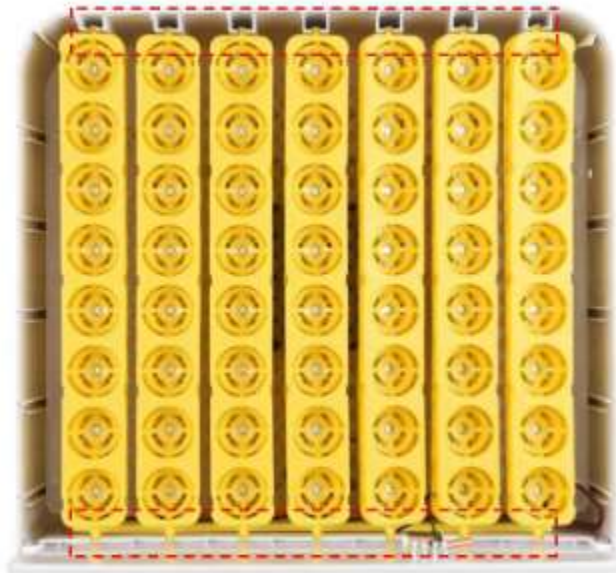

4- Ensure egg tray matched card slot of both sides

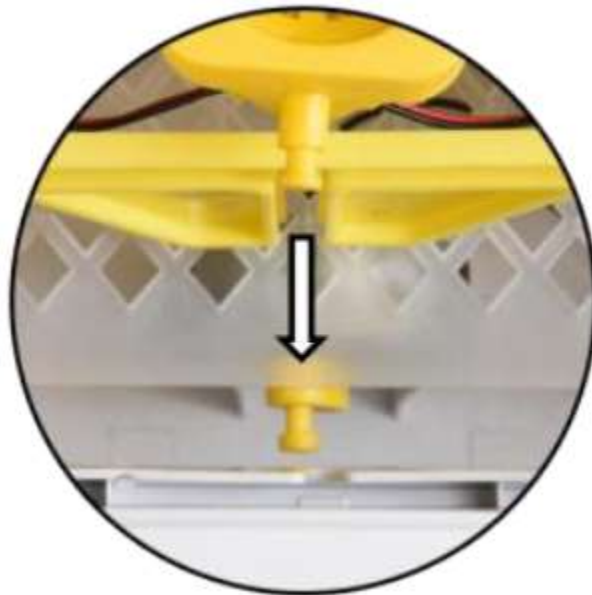

5- Connecting motor interdace

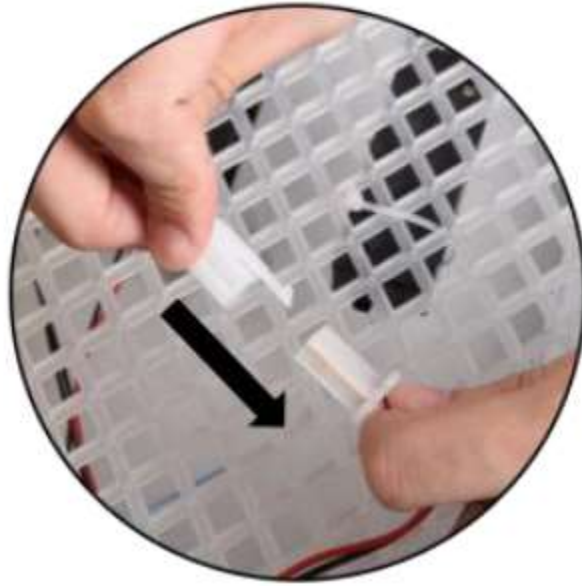

6- Ensure fan, temperature display, function keys, heater and keepworks well.



7- Add water to preheat the incubator and keep 20-30 minutes after checking, then start hatching.



### Operation Interface of controller

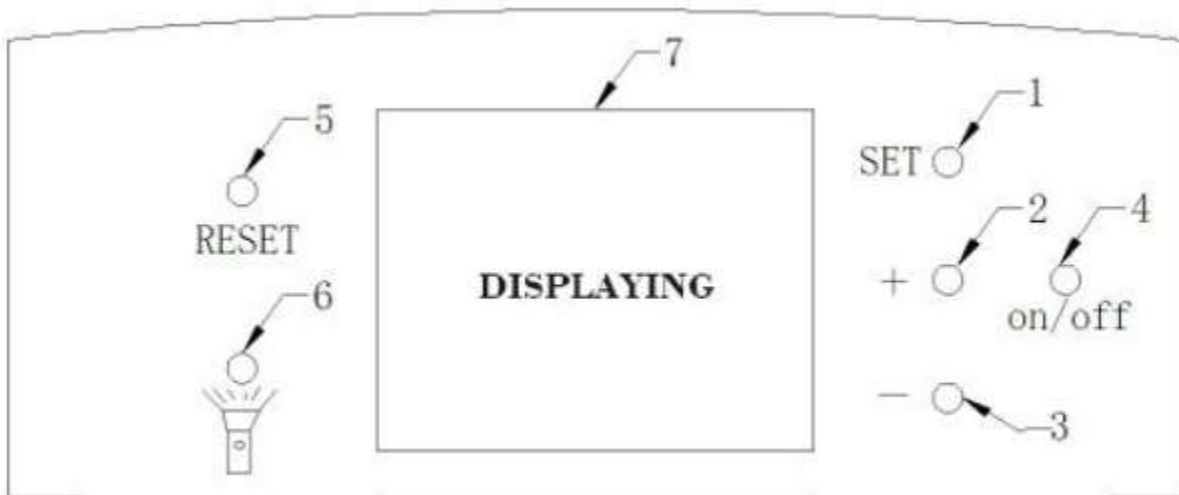

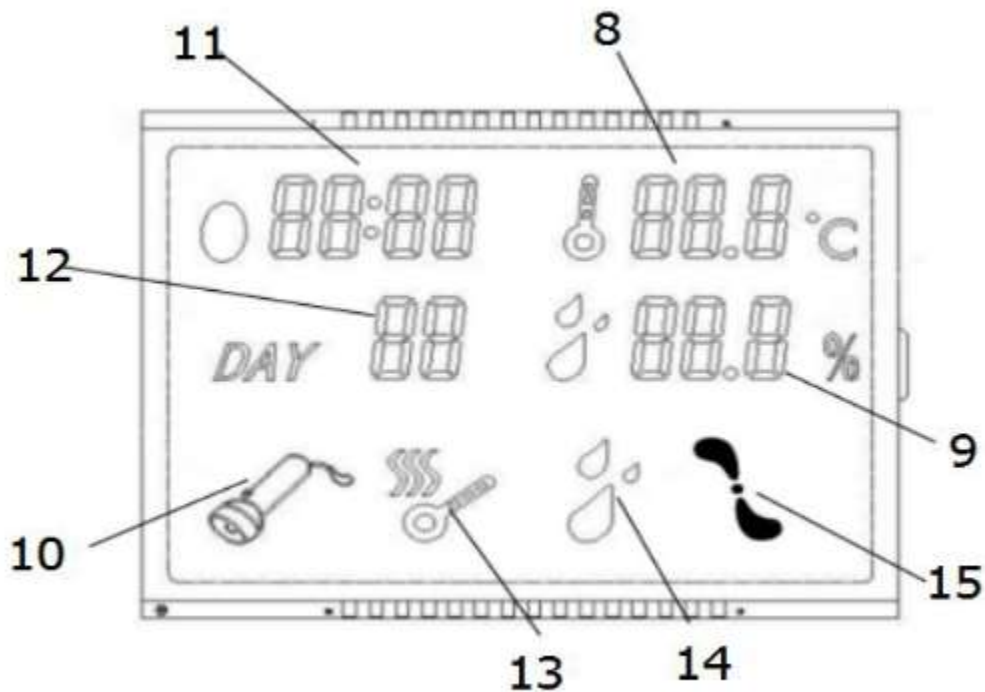

#### Key Function :

- 1- Switch/Setting key (Press the SET button and plug in at the same time to restore factory settings.)
- 2- Increase key/ function selection key
- 3- Decreasing key/ function selection key
- 4- On/Off
- 5- Reset
- 6- Egg candle key (only 56s/32s has this function)
- 7- Display
- 8- Temperature display
- 9- Humidity display
- 10- Testing indicator light
- 11- Display of 2-hour egg turning
- 12- Display of hatching days
- 13- Hatching indicator light (heater work)
- 14- Humidity alarm light
- 15- FAN

#### Setting of controller

## **1- Testing your incubator for the first time:**

- 1-1- Connect the egg turner plug to the control plug.
- 1-2- Connect the provided power wire to your power source.
- 1-3- Switch on your power source.
- 1-4- Switch your incubator on.
- 1-5- You will hear an alarm sounding due to low temperature/humidity, it's normal, don't worry.
- 1-6- Press any of the green buttons to cancel the alarm.
- 1-7- Operate the incubator and filling the water hole you will notice the humidity reading increase.

## **2- Setting the temperature**

- 2-1- Push "temperature setting/Humidity Setting" once.
  - 2-2- Push "+" or "-" to select the desired temperature.
  - 2-3- Push "temperature setting/Humidity Setting" once more to exit.
- These incubators are factory set at 38oC, I found the chicks hatch at day 19 to 20 meaning the temperature being to high. Using the method as described above. I recommend you set the temperature at 37.6oC.

## **3- Temperature alarm parameter settings (AL and AH)**

The temperature alarm is factory set to sound at 1oC over or below the set temperature. This is sufficient and you do not need to make any changes to these settings.

### **3-1- Low temperature alarm parameter setting. (AL)**

- 3-1-1- Press and hold "temperature setting" for 3 sec.
- 3-1-2- Push "+" or "-" until code "AL" appears in the temperature screen.
- 3-1-3- Push "temperature setting"
- 3-1-4- Push "+" or "-" to adjust to your desired lower alarm setting.

### **3-2- Higher temperature alarm parameter setting (AH)**

- 3-2-1- Press and hold "temperature setting" for 3 sec.
- 3-2-2- Push "+" or "-" until code "AH" appears in the temperature screen.
- 3-2-3- Push "temperature setting"
- 3-2-4- Push "+" or "-" to adjust to your desired higher alarm setting.

## **4- Humidity alarm parameter setting(AS)**

The humidity alarm is factory to sound 45% humidity. This is sufficient and you don't need to make any changes to these settings.

- 4-1- Low humidity alarm parameter setting. (AS)
  - 4-2- Press and hold "SETT" for 3 sec.
  - 4-3- Push "+" or "-" until code "AS" appears in the temperature screen.
  - 4-4- Push "SET"
  - 4-5- Push "+" or "-" to your desired lower alarm setting.
- By filling both water channels the humidity should rise 60% depend on the local humidity levels and the time of year. I tend to fill both my water channels every 4

to 5 days at day 18 when I remove the egg trays I over fill them to increase the humidity to about 65%.

### 5- Calibrating temperature sensor reading (CA)

The thermometer correct reading is set at 0oC. The reading given by the thermometer can be adjusted if you find that the temperature reading is incorrect using a calibrated thermometer.

5-1- Calibrating the temperature sensor measurement. (CA)

5-2- Press and hold “temperature setting” for 3 sec.

5-3- Push “+” or “-“ until code “CA” appears in the temperature screen.

5-4- Push “temperature setting”

5-5- Push “+” or “-“ to adjust to the correct measurement.

- Note that the adjustment is the difference between the thermometer readings and should be adjusted with “- “ if the temperature reading of the incubator is to high and normal value (indicating + value) if the incubator reading is too low.

### 6- Temperature Upper and lower limit set (HS and LS)

HS - (High Set) and LS - (Low Set) set the limit of the setting range of the desired temperature setting (incubating temperature adjustment)

If HS is set as 38.2 and LS is set as 37.4, then the desire temperature (incubating temperature adjustment) can only be changed from 38.2 to 37.4, so the minimum temperature shall be limited to 37.2 even if the “-“ is kept on pressing. The same goes for the High Set Limit.

## 7. Display Symbols

Number	Symbol	Meaning	Factory Setting
3.1 above	AL	low temperature alarm parameter setting	1 °C
3.2 above	AH	High temperature alarm	1 °C
4.1 above	AS	Low humidity alarm parameter setting	45%
5.1 above	CA	Calibrating temperature sensor reading	0 °C
6 above	HS	Temperature higher limit set	39.5 °C
6 above	LS	Temperature lower limit set	30 °C

### Notice for first time of incubating

- 1- Test your incubator to see if it functions properly.
- 2- Connect the egg turner plug to the control plug inside the egg compartment.
- 3- Fill one or both water channels depending on local humidity levels.
- 4- Set the eggs with the pointy side down.
- 5- Close the lid and switch on the incubator.
- 6- Press the reset button (left green button) to reset and start the day counter from

“0”.

(this will also reset the egg turning countdown back to 1:59)

7- Keep an eye on the humidity reading and fill the water channels when needed.  
(normally every 4 days)

8- At day 18 you should remove the tray with the turning mechanism and place the eggs on top of the bottom grid.

9- At the same time it is important to fill water channels to increase the humidity.  
(this is very important to ensure that the eggshells are soft enough for the chicks to break through.)

10- Don't open the lid frequently when the chicks start to hatch, you could fill water through kettle. If you do, the loss of humidity will cause the eggshells of the unhatched eggs to dry out and they won't be able to break through the egg.

## **Incubating tips**

The first step for hatching is choosing the best fertilized eggs. Then how to choose?

1- Fertilized Eggs must be fresh and generally within 4-7 days after laying is the best. The best temperature for saving fertilized eggs is 10-15°C. The fertilized egg is covered with a layer of powdery substance, which is strictly prohibited to put into the fridge and wash.

2- The surface of the egg shell is required to be free of deformity, cracks or any spots.

3- There's no need to be very careful on disinfecting fertilized eggs. Do not go to disinfect if you can't achieve disinfection conditions because improper disinfection may reduce the hatching rate. Just make sure the egg surfaces are clean and free of spots.

4- When putting eggs into the machine for hatching, make sure the pointed side is down.

5- Proper operation and careful observation are required during the incubation, such as: add water to the machine every 1 to 2 days (it depends on the environment and the content of water inside the machine).

6- Fertile eggs can't be tested by an egg candler in the first four days during hatching, to avoid the incubator and egg surface temperature decline sharply affecting the eggs' early development.

7- The first time to test an egg (5 to 6 days): mainly to check the fertilization of the eggs, select the unfertilized eggs, scattered yellow eggs, dead eggs.

The second time to test an egg (11 to 12 days): mainly to check the development of the egg embryo, the well-developed embryo is enlarged, with blood vessels inside, and the air chamber is large and sharply demarcated.

The third time to test an egg (16 to 17 days): Light from the pointed side, a well-developed embryo is larger, meanwhile full of egg, and no light in most places. If it's a dead egg, the blood vessels in the egg are blurred, parts yellow near the air chamber, the boundary between the egg and the air chamber is not clear.



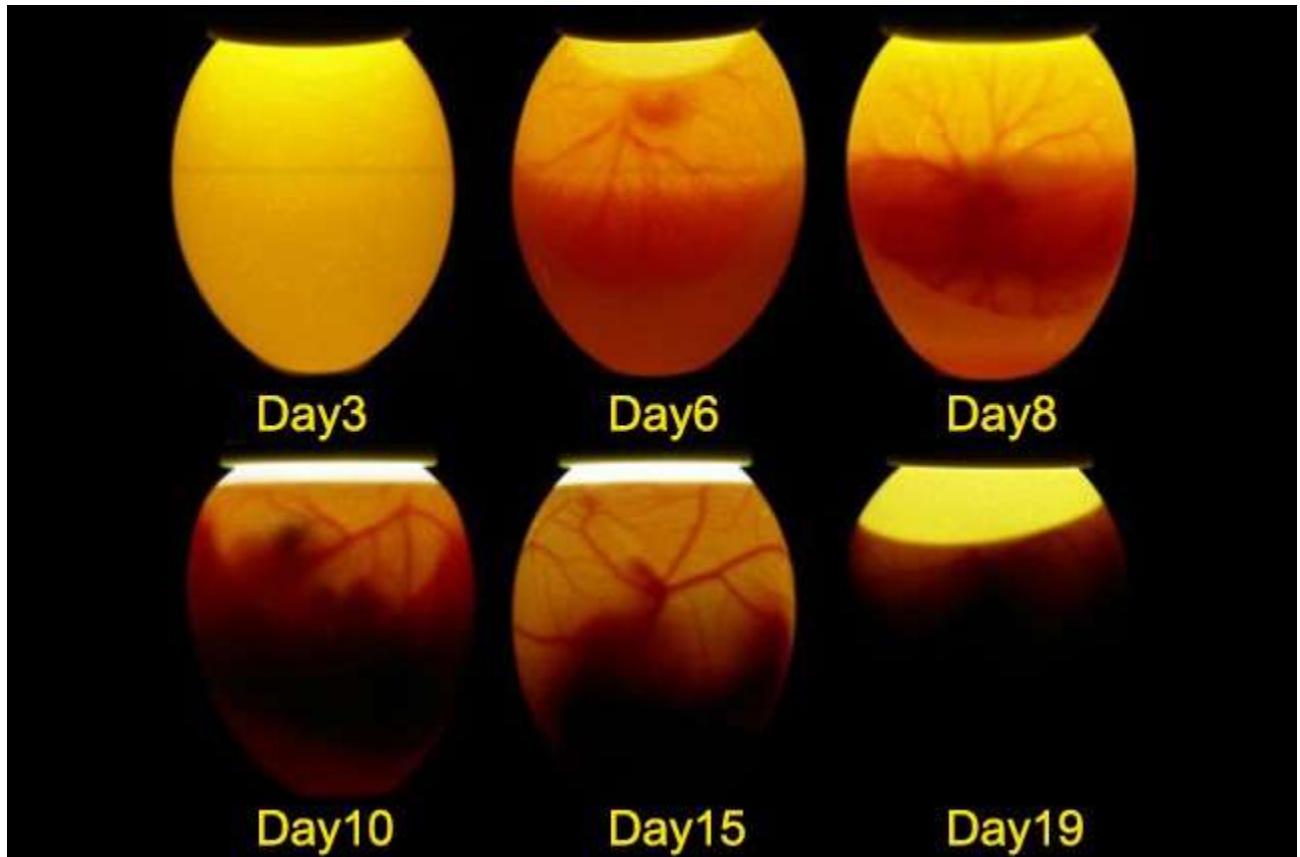

8- Increase humidity and decrease temperature during hatching period , it prevents water from evaporating too quickly in the eggs. Most importantly ,increase humidity , prevent dehydration and reduce the temperature to avoid high temperature and high humidity, especially the hatching period last for a long time. And the temperature should be no more than 37.5°C in 19th-21th days.

1- Egg and incubator hygiene

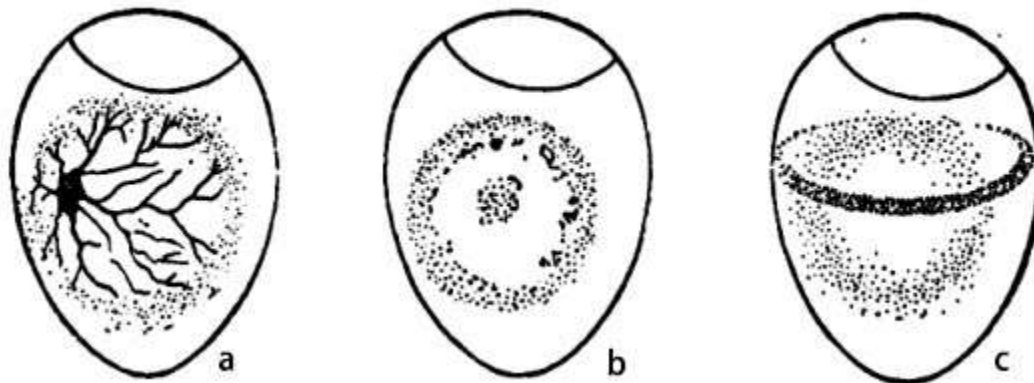

Proper hygiene is essential to achieve good hatching results. Poor hygiene causes chicks to die in their first 10 days of life.

Only clean eggs should be used for incubation. Dirty eggs are potential carriers of diseases that thrive and multiply in the ideal heat and moisture conditions of the incubator. If you need to incubate dirty eggs, wash them first in warm water (44-49 °C) that contains disinfectant at a rate recommended by the manufacturer (most household disinfectants are suitable), and dry the eggs quickly after washing using separate paper towels.

Do not soak eggs for longer than four minutes to avoid affecting fertility and do not soak eggs in cold water, as it encourages bacterial penetration through the eggshell. Fumigating eggs immediately after collection also helps with hygiene. A suitable fumigant is formaldehyde gas, which is made by mixing 1 part (by weight) of potassium permanganate (Condy's crystals) with 1.5 parts (by volume) of formalin (see Table 1 for the correct amounts for each application). Place the chemicals in a dish on the floor of the incubator. Place the Condy's crystals into the dish first and then pour the formalin over it. Shut the incubator door quickly and vacate the room. For proper fumigation, run the machine normally with the correct temperature and humidity. After 20 minutes, open the vents or the door and air the machine for a few minutes. Again, vacate the room.

## **2- Healthy stock**

It is important that eggs from only a healthy flock are used for hatching, as some diseases can be transmitted through the egg. The egg-transmittable diseases to be most aware of are salmonella infections, fowl typhoid and *Mycoplasma gallisepticum*.

Eggs laid by birds infected with disease may fail to hatch. Of those that do hatch, some birds may die during brooding, and the survivors may act as carriers and infect healthy chicks.

Do not add eggs from unknown sources to make up numbers, as you risk infecting your flock.

Breeding stock nutrition

The egg provides a complete food store for proper embryo development except gaseous oxygen, which enters the egg through pores in the shell. Breeding stock must be fed a well-balanced diet to fully meet the embryos' nutrient requirements. The deficient nutrients are usually vitamins or minerals. A deficiency of these in the breeders' diet may not show any ill effects in the breeders, though hatchability may be affected, which is why different categories are fed specific diets. Nutritional deficiencies, such as a lack of riboflavin, are the main causes of embryo mortality during the middle stage of incubation (i.e. between the 12th and 14th days). Hens' vitamin and mineral requirements for laying eggs are lower than those of breeders. The breeder's diet should begin six to eight weeks before hatching eggs are required, with particular attention to vitamin A, D3, riboflavin, pantothenic acid, biotin, folic acid, vitamin B12 and the mineral manganese.

Deficient nutrient	Result
<b>Riboflavin</b>	Leads to poor hatchability with a high incidence of malformed embryos, which are excessively moist
<b>Pantothenic acid</b>	Lowers hatchability and causes a high incidence of apparently normal embryos to die over the last two or three days of incubation
<b>Biotin, choline and manganese</b>	Leads to abnormal development of the embryo and a condition known as enlarged hock/slipped Achilles tendon
<b>B12</b>	Leads to a rapid decrease in hatchability and a progressively poorer survival of chicks that do hatch

### Problem : 1- Too many clears or infertile eggs

Probable causes	Action
(a) Wrong proportion of males to females	(a) Check mating ratios according to breeder's recommendations
(b) Male is undernourished	(b) See that cockerels are able to feed separately, otherwise hens may eat all the feed
(c) Interference among males during mating	(c) Do not use too many males; always rear breeding males together; erect temporary solid partitions between breeding pens or inside large pens
(d) Damaged combs and wattles among males	(d) See that housing is comfortable and proper drinking fountains are provided for breeding pens
(e) Male is too old	(e) Replace old birds
(f) Male is sterile	(f) Replace with another male
(g) Eggs kept too long or under the wrong conditions before setting	(g) Do not keep hatching eggs longer than seven days; store them in a cool temperature (10-15.6°C) at relative humidity around 75-80%

### Problem : 2- Blood rings, which indicate very early embryonic death

Probable causes	Action
-----------------	--------

<b>(a) Incubator temperature too high or low</b>	(a) Check thermometers, thermostats and electricity supply; follow manufacturer's instructions
<b>(b) Incorrect fumigation procedure</b>	(b) Use the correct amount of fumigant. Do not fumigate between 24 and 96 hours after setting
<b>(c) As in 1(g)</b>	(c) As in 1(g)

**Problem : 3- Many dead-in-shell**

Probable causes	Action
<b>(a) As in 2(a)</b>	(a) As in 2(a)
<b>(b) Eggs not properly turned</b>	(b) Turn the eggs regularly at least three to five times a day; always turn the eggs in the reverse direction each time
<b>(c) Breeding stocks' nutrition is deficient if deaths are high in days 10 and 14</b>	(c) Check that feeding is sound
<b>(d) Incubator's ventilation faulty</b>	(d) Increase ventilation by normal means
<b>(e) Infectious diseases</b>	(e) Use eggs only from healthy stock; check that hatchery hygiene is sound and carried out regularly

**Problem : 4- Piped eggs failing to hatch**

Probable causes	Action
<b>(a) Insufficient moisture in the incubator</b>	(a) Increase the evaporating surface of water or the sprays
<b>(b) Too much moisture at earlier stages</b>	(b) Check wet-bulb readings
<b>(c) Nutrition problem</b>	(c) Check flock feeding

**Problem : 5- (a) Hatching too soon, (b) Hatching too late, (c) Sticky chicks**

Probable causes	Action
<b>(a) Incubator's temperature too high</b>	(a) Ensure the temperature regulating gear is working and set at the correct operating temperature when the control switches off
<b>(b) Incubator's temperature too low</b>	(b) Ensure the temperature regulating gear is working and set at the correct operating temperature when the control switches off
<b>(c) Incubator's temperature probably too high</b>	(c) Ensure the temperature regulating gear is working and set at the correct operating temperature when the control switches off

**Problem : 6- Malformed chicks**

Probable causes		Action
(a) Incubator's temperature too high		(a) As in 2(a)
(b) Incubator's temperature too low		(b) As in 2(a)
(c) Eggs set incorrectly or not properly turned after setting		(c) As in 3(b); also, take care to set the eggs broad-end up;

**Problem : 7- Spraddling chicks**

Probable causes		Action
Hatching trays too smooth		use wire-meshed tray floors or cover slippery floors with burlap or other similar material

**Problem : 8- Weak chick**

Probable causes		Action
(a) Incubator or hatching unit overheating		(a) Ensure the temperature regulating gear is working and set at the correct operating temperature when the control switches off
(b) Setting small eggs		(b) Only set eggs of the breed average size

**Problem : 9- Small chick**

Probable causes		Action
(a) Too little moisture in incubator		(a) Check flock feeding
(b) Too much fumigant left in hatcher		(b) Use the correct amount of fumigant. Do not fumigate between 24 and 96 hours after setting

**Problem : 10- Heavy breathing chicks**

Probable causes		Action
(a) Too much moisture in hatcher		(a) As in 4
(b) Possibly infectious disease		(b) Send chicks to a veterinary laboratory for diagnosis
(c) Low average temperature during period of incubation		(c) Check thermometers, thermostats and electricity supply; follow manufacturer's instructions

**Problem : 11- Mushy chicks**

Probable causes	Action
-----------------	--------

<b>(a) Incubator has poor ventilation</b>	(a) Omphalitis (navel infection)
<b>(b) Incubator's ventilation faulty</b>	(b) Carefully clean out and fumigate the incubator using formaldehyde at the higher strength; disinfect all equipment;

**Problem :12- Hatch not coming off evenly**

Probable causes	Action
<b>(a) Setting eggs too diverse in age or size</b>	(a) set eggs at least once a week and never retain hatching eggs longer than 10 days before setting; incubate only average-size eggs

**Some questions may meet when incubating your eggs**

**1- How must I store eggs?**

Your eggs need to settle for at least 24 hours if they came through the post. This allows the air cell inside the egg to return to its normal size. Eggs should always be stored with the pointy end down while they are "in the hold". It's a good practice to follow and it will help your hatch!

If you receive eggs that are getting old, you may only let them settle overnight.

**2- When is my incubator ready to start incubating?**

By the time you have gotten your eggs your incubator should have been running at least 24 hours. A week is even better. This gives you time to learn what's going to happen in your incubator and allows you to make any necessary adjustments before setting your eggs. A surefire way to ruin hatching eggs is to put them in the incubator without having it properly adjusted.

Take note of the term "internal" temperature. Don't confuse internal egg temperature with internal incubator temperature. The temperature in an incubator changes constantly, rising and lowering. The temperature inside the egg will be an average of this temperature swing in your incubator.

**3- What must the temperature and humidity be inside my incubator?**

This is plain and simple, yet the MOST important part of hatching.

Fan Forced incubator: 37.5 °C measured anywhere in the incubator.

Humidity: 55% for the first 18 days, 60-65% for the last 3 days in the hatcher.

**4- Is my thermometer accurate?**

Thermometers go bad. Keeping the temperature accurate can be a struggle, even with very good thermometers. A nice part about running a big incubator over an extended period is that you can tweak the temperature regardless of what thermometers tell you.

After the first hatch, you can raise or lower the temperature by what the hatch tells

you. If they hatched early the temperature needs to be lowered. If they hatch late the temperature needs to be raised.

You can check your Thermometer this way. Keep notes on everything you do during the incubation period. As you learn you'll have these notes to look back on. They will be the most valuable tool that you can have. It won't be long until you can say "I know what happened, all I need to do is change this one little thing". Soon you will be able to make adjustments by knowing what to do, instead of guessing!!!

### **5- How do I check humidity?**

Humidity is checked by way of a hygrometer (wet-bulb thermometer) in conjunction with a regular "dry-bulb" thermometer. A hygrometer is simply a thermometer with a piece of wick attached to the bulb. The wick hangs in water to keep the bulb wet (hence the name "wet-bulb thermometer"). When you read the temperature on the thermometer and hygrometer, you must then compare the readings to a chart to translate from wet-bulb/dry-bulb reading to "percentage humidity".

From the relative humidity table, you can see.....

60% humidity reads about 30.5 °C on a wet-bulb at 37.5 °C.

60% humidity reads about 31.6 °C on a wet-bulb at 38.6 °C.

80% humidity reads about 33.8 °C on a wet-bulb at 37.5 °C.

80% humidity reads about 35 °C on a wet-bulb at 38.6 °C.

Getting your humidity to become as accurate as your temperature is nearly impossible. It is almost completely impossible with a small incubator. Try to get your humidity as close as you can, and you'll be fine. Just being aware that humidity is important, and trying to get the numbers to come in close will be a huge help to your hatch.

If you can hold within 10-15% things should turn out fine.

Temperature on the other hand, is CRITICAL!!!! We hate to beat this point to death, but a small deviation in temperature (even a couple degrees) can and will ruin a hatch. Or, at least turn a potentially great hatch into a lousy one.

### **6- An important point about incubator humidity**

As seasons change, so goes humidity. When you are incubating eggs in January and February it will be very difficult to maintain a humidity that is as high as you like. That's because the outside humidity is so low. (Depending on where you live). By the same token, when you are incubating in June and July the outside humidity is usually much greater and the humidity in your incubator will most likely get much higher than you would like. Hatching problems will change as the season progresses. If you are doing things the same way in July as you were in January, you have to expect different results. All we are trying to say here is that your incubator humidity changes directly according to the outside humidity. Low outside, low in the incubator. High outside, high in the incubator. To adjust for these problems, you need to change the surface area of water in your incubator.

### **7- What is surface area?**

Surface area is "the amount of surface of water exposed to air in your incubator". The depth of water has absolutely no bearing on the humidity in the incubator (unless the depth is zero). If the humidity is too low in your incubator, add surface area. Place another pan of water in the incubator, or some small, wet sponges. This will help. Alternatively you can spray the eggs with a fine mist. To decrease the humidity, remove surface area. Use smaller containers of water, or undo some of the things you've added.

### **8- How long will it take to incubate chicken eggs?**

The incubation period for chicken eggs is 21 days. You should turn your eggs at least three times a day for the first 18 days, and stop turning after the 18th day (or use a hatcher if you have eggs from different days in the same machine). This allows the chick time to orient itself inside the egg before piping.

After day 18, **KEEP THE INCUBATOR CLOSED** except to add water. This will help bring the humidity up to help the chicks hatch. I know it will kill you not to open the incubator 1000 times when it's this close to hatch time, but it's not good for the chicks. If you haven't bought an incubator yet, invest the extra couple bucks in the picture window model. Then you can "see it all" without causing harm to your hatch.